

INNOVATIVE DESIGN FOR AIRCRAFT LANDING GEARS

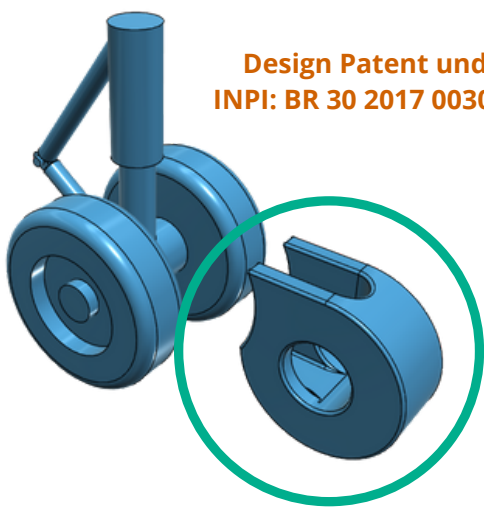

Design Patent under
INPI: BR 30 2017 003006 8

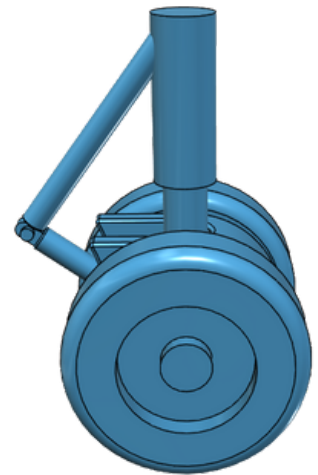
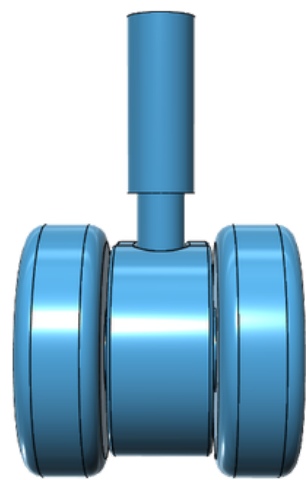

Vortex generated on
the flow by design
(Obs: CFD RANS
simulated)

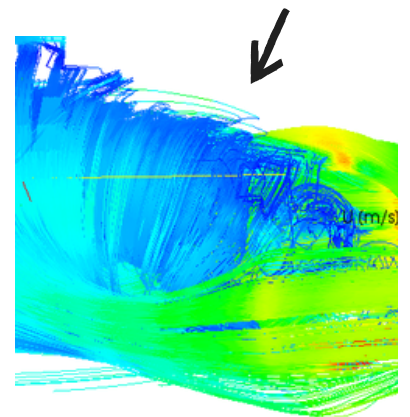
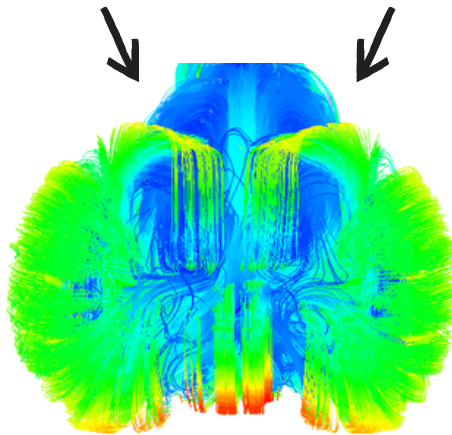

Front and rear pressure
difference with design.
Estimated drag reduction:
15% to 20%

